

2902,2903,2908,2914 TRIM INSTRUCTIONS

(SEE TEMPLATE FOR DOOR PREPARATION)

RIM CYLINDER INSTALLATION

2903 TRIM

KIT NUMBER CA-3903

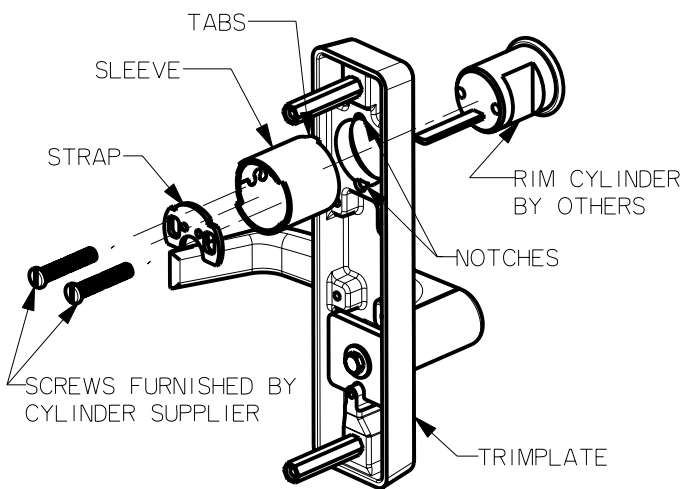

- 1) INSERT RIM CYLINDER INTO TRIM.
- 2) POSITION SLEEVE BY PLACING TABS INTO THE NOTCHES IN THE TRIM PLATE.
- 3) PLACE STRAP ON THE SLEEVE.
- 4) SECURE CYLINDER BY TIGHTENING SCREWS.

MORTISE CYLINDER INSTALLATION

2908 TRIM

KIT NUMBER CA-2908

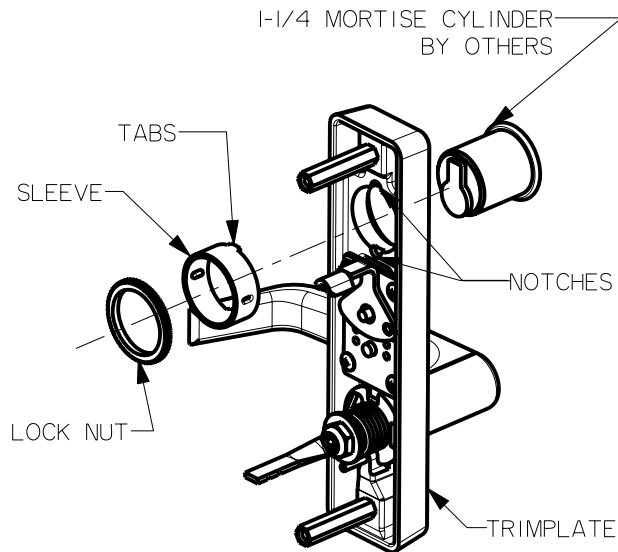

- 1) INSERT MORTISE CYLINDER INTO TRIM.
- 2) POSITION SLEEVE BY PLACING TABS INTO THE NOTCHES IN THE TRIM PLATE.
- 3) SECURE CYLINDER BY TIGHTENING LOCK NUT.

TRIM INSTALLATION

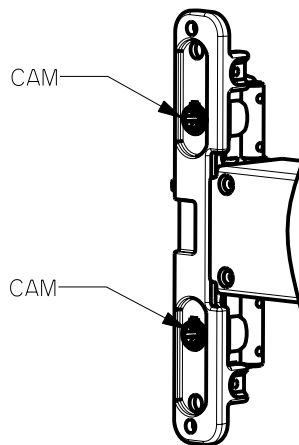
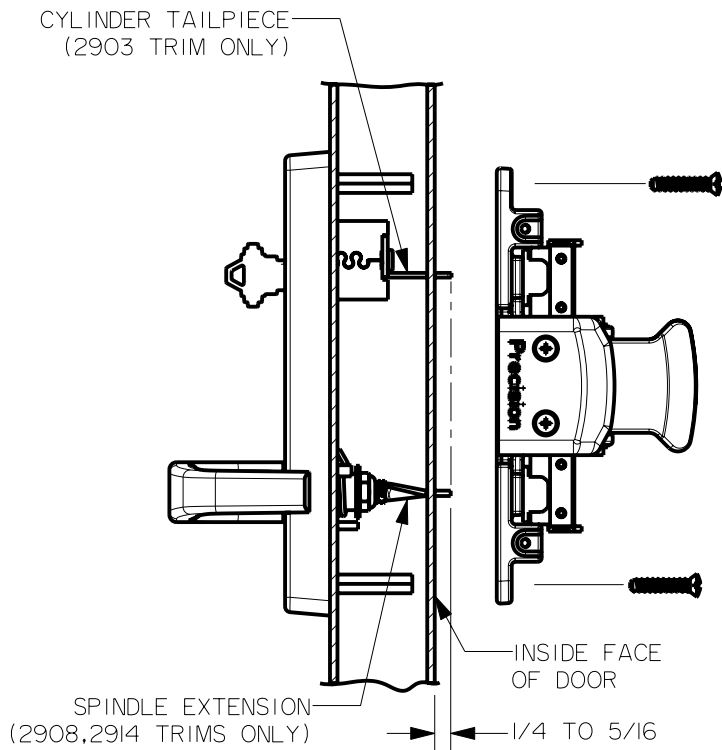

INSERT CYLINDER TAILPIECE INTO THE CAM OR SPINDLE EXTENSION INTO CAM

SECURE THE CHASSIS TO THE TRIM WITH SCREWS

2902,2903,2908,2914 TRIM INSTRUCTIONS

(SEE TEMPLATE FOR DOOR PREPARATION)

CHANGING HAND

HANDING CHANGE 2902 AND 2903 TRIM

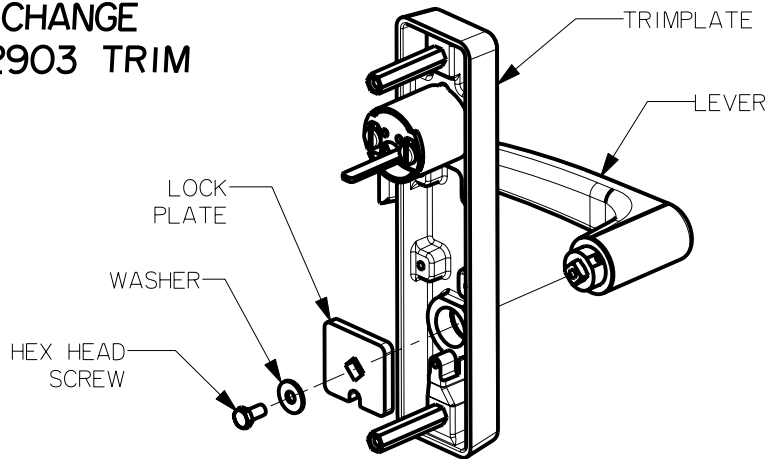

- 1) REMOVE SCREW AND WASHER.
- 2) PULL LEVER OUT OF LOCK PLATE AND ROTATE 180°
- 3) INSERT LEVER INTO THE LOCK PLATE AND ATTACH WITH SCREW AND WASHER.

HANDING CHANGE 2908 AND 2914 TRIM

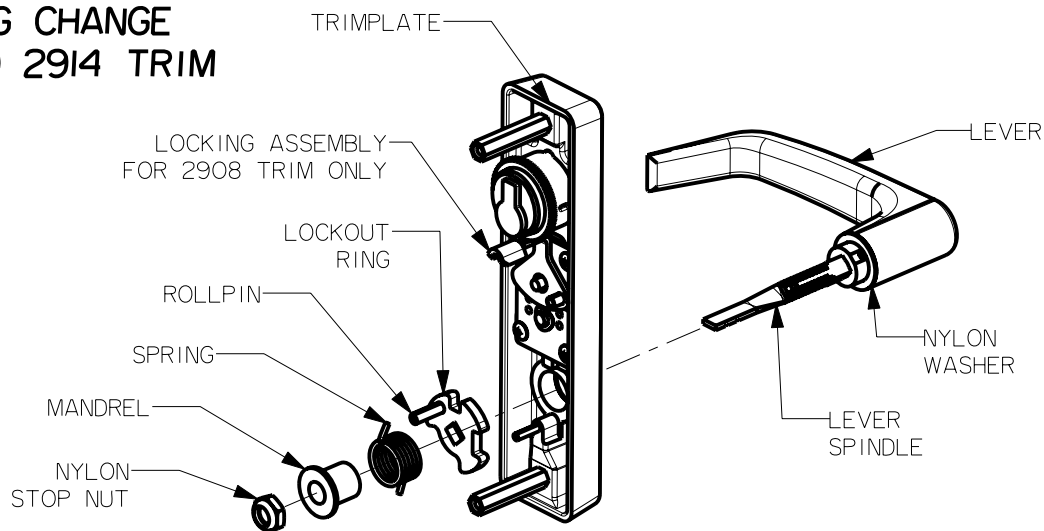

- 1) REMOVE LEVER, LOCKOUT RING, SPRING AND MANDREL BY REMOVING NYLON NUT.
- 2) PUSH ROLLPIN THROUGH TO THE OPPOSITE SIDE OF LOCKOUT RING.
- 3) ROTATE LEVER 180°, INSERT LEVER WITH NYLON WASHER INTO THE TRIMPLATE.
- 4) INSERT LOCKOUT RING ON THE LEVER SPINDLE, MAKE SURE ROLLPIN IS POINTING TOWARDS YOU.
- 5) PLACE SPRING WITH LOWER SPRING LEG AGAINST STOP IN TRIMPLATE AND MANDREL ON TO THE LEVER SPINDLE. LOAD SPRING BY PLACING UPPER SPRING LEG AGAINST THE ROLLPIN IN THE LOCKOUT RING, AND SECURE IT BY TIGHTENING THE NYLON NUT.

NOTE: IF LEVER DOES NOT MOVE FREELY
LOOSEN THE NYLON NUT SLIGHTLY.

STANLEY

phi

DRWG 01821-11-000 DATE 04/01/03 REVISION A

Precision Hardware
a Division of Stanley Security Solutions, Inc.
www.stanleysecuritysolutions.com