

3900 SERIES TRIM CONVERSION

(SEE TEMPLATE FOR DOOR PREPARATION)

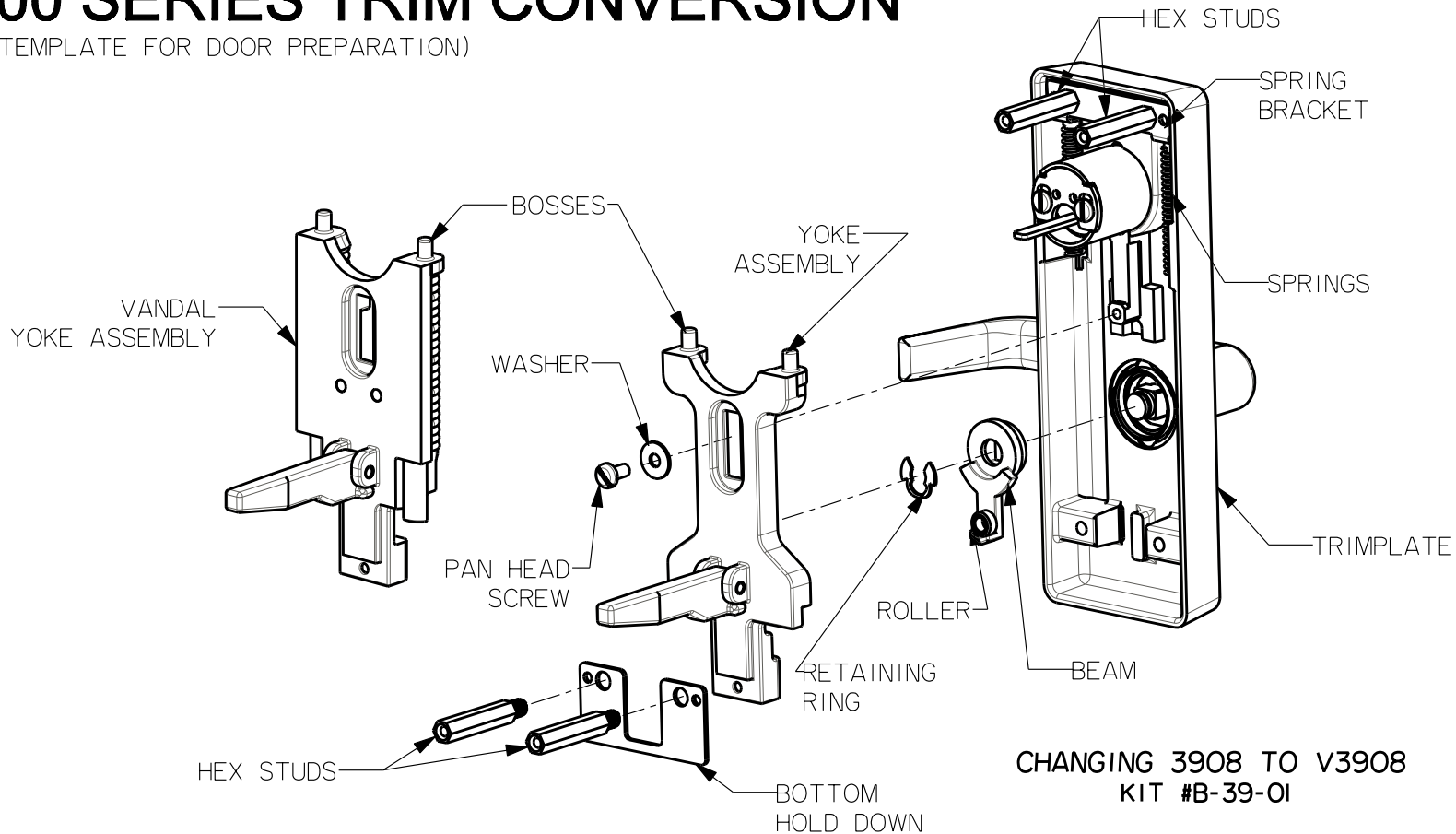

CHANGING 3902/3903 TRIM TO 3908/3914 KIT #FC-08 OR VFC-08

DISASSEMBLE

- 1) DISENGAGE BEAM FROM LEVER BY REMOVING RETAINING RING
- 2) REMOVE TOP AND BOTTOM HEX STUDS

REASSEMBLE

- 1) ROTATE BEAM 180° AND SECURE IT TO THE LEVER WITH RETAINING RING. PLACE ROLLER ONTO THE BEAM.
- 2) SPRING BRACKET AND SPRINGS WITH TOP STUDS AS SHOWN.
- 3) INSERT YOKE BOSSES INTO SPRINGS AND PUSH UP TO SEAT YOKE ASSEMBLY INTO THE TRIMPLATE AND SECURE WITH SCREW AND WASHER.
- 4) SECURE BOTTOM HOLDDOWN WITH HEX STUDS.

CHANGING 3908 TO V3908 KIT #B-39-01

DISASSEMBLE

- 1) REMOVE BOTTOM HEX STUDS AND HOLDDOWN.
- 2) PULL OUT YOKE ASSEMBLY BY REMOVING SCREW AND WASHER.

REASSEMBLE

- 1) INSERT VANDAL YOKE BOSSES INTO SPRINGS AND PUSH UP TO SEAT YOKE ASSEMBLY INTO THE TRIMPLATE AND SECURE WITH SCREW AND WASHER.
- 2) SECURE BOTTOM HOLDDOWN WITH HEX STUDS.



DRWG 01835-11-000 DATE 04/01/03 REVISION A
Precision Hardware, Inc.
 P.O. Box 74040, Romulus, MI 48174-0040
www.precisionhardware.com