

**SEX BOLT MACHINING**  
 DRILL 1/4 DIA. INSIDE  
 DRILL 5/16 DIA. OUTSIDE

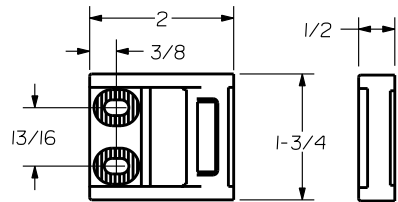

ROLLER STRIKE S988  
(STANDARD)

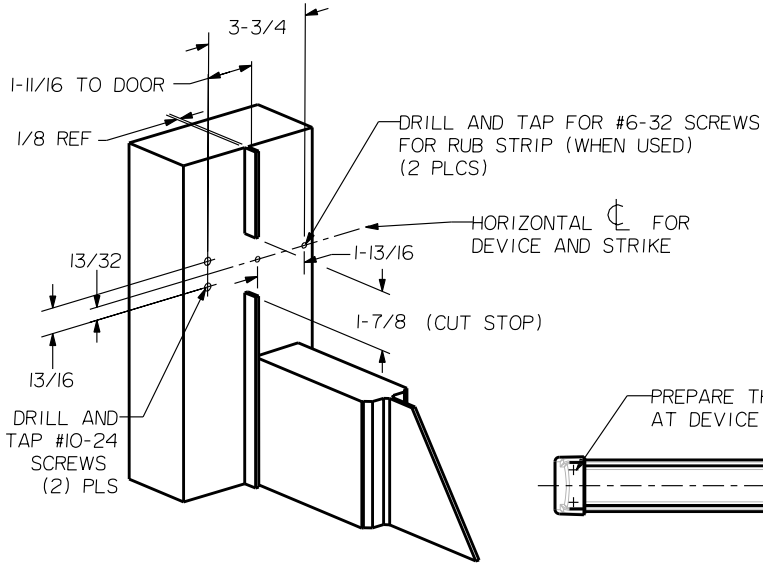
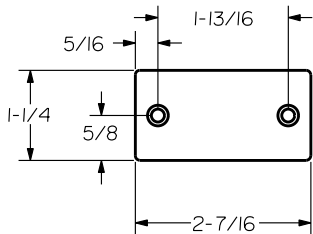

RUB STRIP S454  
(STANDARD)



DEVICES	TRIMS	HOLE A (2) PLS	HOLE B
51	808	5/16 DIA THRU DOOR	1" DIA. THRU DOOR
	814		

**LOCK STILE MACHINING**

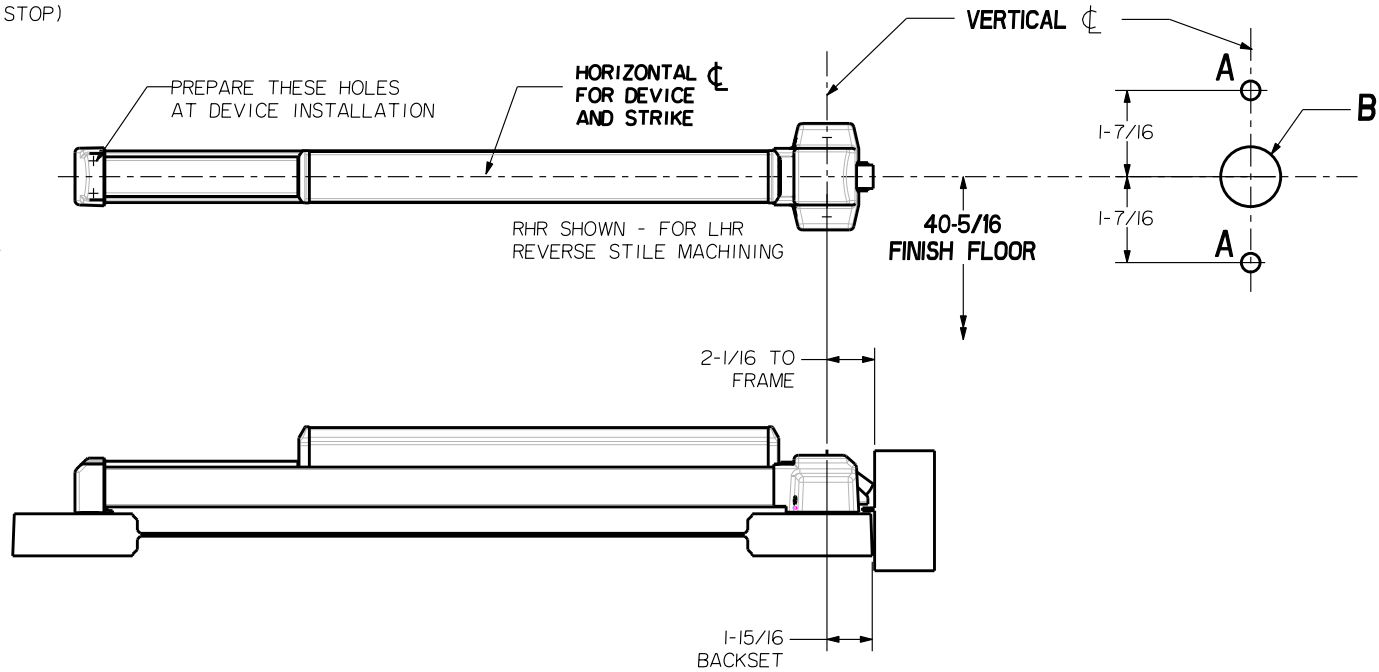

ALUMINUM DOOR AND FRAME WITH BLADE OR APPLIED STOP		
MIN. STILES	DEVICE SIZE	DOOR WIDTH
3-3/4"	3'-0"	2'-6" TO 2'-11"
	4'-0"	3'-0" TO 3'-11"
4-1/4 OR FLUSH DOOR	3'-0"	2'-7" TO 3'-0"
	4'-0"	3'-1" TO 4'-0"

PRECISION HARDWARE INC. WWW.PRECISIONHARDWARE.COM			
DEVICE SERIES		TRIM SERIES	
51		808,814	
STRIKE NO.	RELEASED DATE	TEMPLATE NO.	REV
S988	04/01/03	AL-51B	A